

SOLUTION

BLANKING

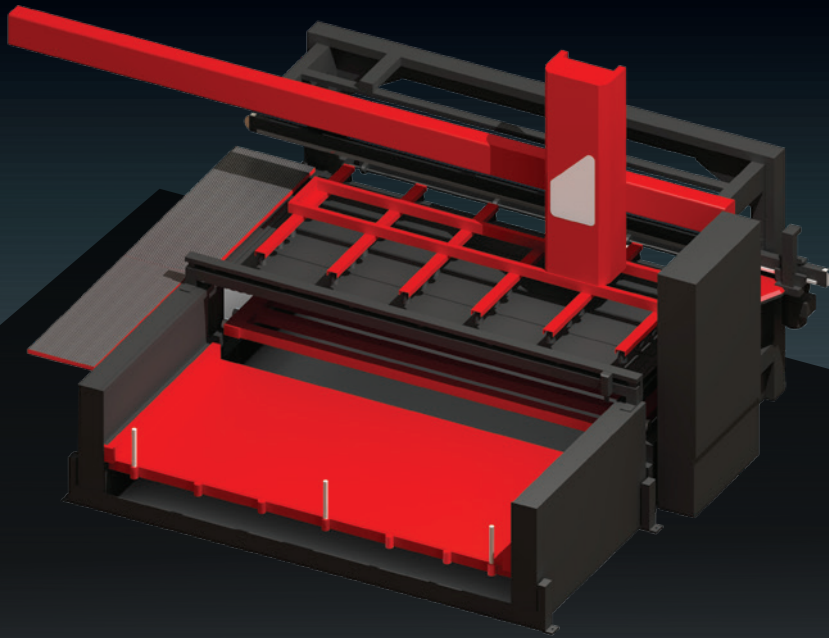

MP SheetCat



SMOOTH AND EFFICIENT HANDLING OF VARIOUS BATCH SIZES

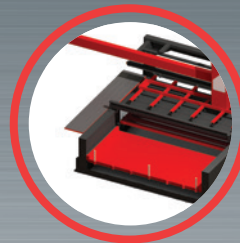

AMADA[®]

DATA SHEET

MP SheetCat

SMOOTH AND EFFICIENT HANDLING OF VARIOUS BATCH SIZES

EM MII | EMZR B/T | AE | LC C1 | Alpha Laser | EM

SMOOTH AND EFFICIENT HANDLING

MP SheetCat offers increased productivity using unmanned loading and unloading of sheets utilising minimal space. Enhanced flexibility and functions for small batches, rush jobs and medium batches create an efficient total solution.

Divided safety zones provide a safe working environment, while at the same time maximizing the utilisation of the NCT / laser. This allows additional jobs to be prepared with the minimum interruption of machining. Efficient and ergonomic handling of rush jobs. Quality checks and part separation on the support table.

Traditional manual stand alone NCT/laser operations reduced by semi-automatic loading and unloading. AMNC Scheduler adds flexibility for the control of the production cell.

Suction cups allow loading of different material types including steel, aluminium, etc ...

Job exchange time is minimized through simultaneous loading and unloading.

A single raw material pallet with possibilities to make job schedules with mixed sheet formats and types.

Smooth unloading of microjointed sheets on a fixed lifting table.

TECHNICAL SPECIFICATIONS

	MP SheetCat 2512*	MP SheetCat 3015
For AMADA model	EM-2510 / EM-3510 AE-2510 LC-2012C1 EML-3510 EMZR B/T-3510 EM MII-3510	EM-3610 EML-3610 AE-2610 LC-2415 α5 EMZR B/T-3612 EM MII-3612
Sheet size	max. min.	
	2 500 x 1 250 mm 700 x 300 mm	3 050 x 1 525 mm 1 000 x 300 mm
Sheet thickness ^{1) 2)}	0.8-6.0 (please refer to laser machine specification)	
Maximum lifting capacity	250 kg	300 kg
Cycle time (continous production)	max.~35 s	max.~37 s
Maximum material mass / pallet	3 000 kg	
Maximum stack height / pallet	300 mm	
Separation magnets / pallet	3 pcs	
Suction cups	30 pcs	34 pcs
Loader traverse speed	max.	1 m/s
Unloader traverse speed	max.	0.5 m/s
Stacking table max load	4 000 kg	
Stacking table max stack height	300 mm	

1) If not max weight limit exceeded 2) Can be limited by machine specifications *Not standard - on request

AMADA UK LTD.

Spennells Valley Road,
Kidderminster,
Worcestershire DY10 1XS
United Kingdom
Tel: +44 (0)1562 749500
Fax: +44 (0)1562 749510
www.amada.co.uk

AMADA SA

Paris Nord II
96, avenue de la Pyramide
93290 Tremblay en France
France
Tél : +33 (0)1 49 90 30 00
Fax : +33 (0)1 49 90 31 99
www.amada.fr

AMADA GmbH

Amada Allee 1
42781 Haan
Germany
Tel: +49 (0)2104 2126-0
Fax: +49 (0)2104 2126-999
www.amada.de

AMADA ITALIA S.r.l.

Via Amada I., 1/3
29010 Pontenure
(Piacenza)
Italia
Tel: +39 (0)523-872111
Fax: +39 (0)523-872101
www.amada.it

